



Owner's Manual



Thermal TD50 - 30 Amp & 3 Phase Mark 5

Dish Washing Machine



WEE/DE2076RU

Machines are manufactured to ISO 9001 : 2008





Index

Thermal TD50 Dish Washer Operating Instructions.....	3
Preparation (TD50)	3
Filling (TD50)	4
Washing (TD50)	5
Close Down Cycle (TD50)	7
Chemical Injection and Warnings	8
Spraybar Rotation Warning	8
Spraybar Rotation Warning	9
Other Features	10
Daily Maintenance.....	11
Vital Parts To Be Regularly Cleaned / Maintained.....	13
Caring For Your Dish Washer	14
Simple Fault Finding.....	16
Machine Errors	21
Dish Washer Installation.....	24
WEEE	31
Service And Warranty.....	32
Warranty	32
Service	34
Disclaimer	35

Thermal TD50 Dish Washer Operating Instructions

Preparation

- Ensure that the machine interior is clean and soil-free, and that the top and bottom spray bars rotate freely, and jets are clean and correctly located.
- Ensure that all four filters are in position in the wash tank trough:

Primary **Flat Disc Filters** (2) are fitted to the wash and waste outlets. Secondary **Drum Filter** fitted over the wash outlet (left-hand outlet). Main **Tray Filter** that encloses the wash tank trough.

- Check that the detergent and rinse aid containers have sufficient liquid level and that the suction tubes are in their appropriate products. **Blue Tube** for rinse aid, and **Clear Tube** for detergent.
- Switch on the water and electrical supplies to the machine. Close the door.

The Select Switch will be illuminated red.

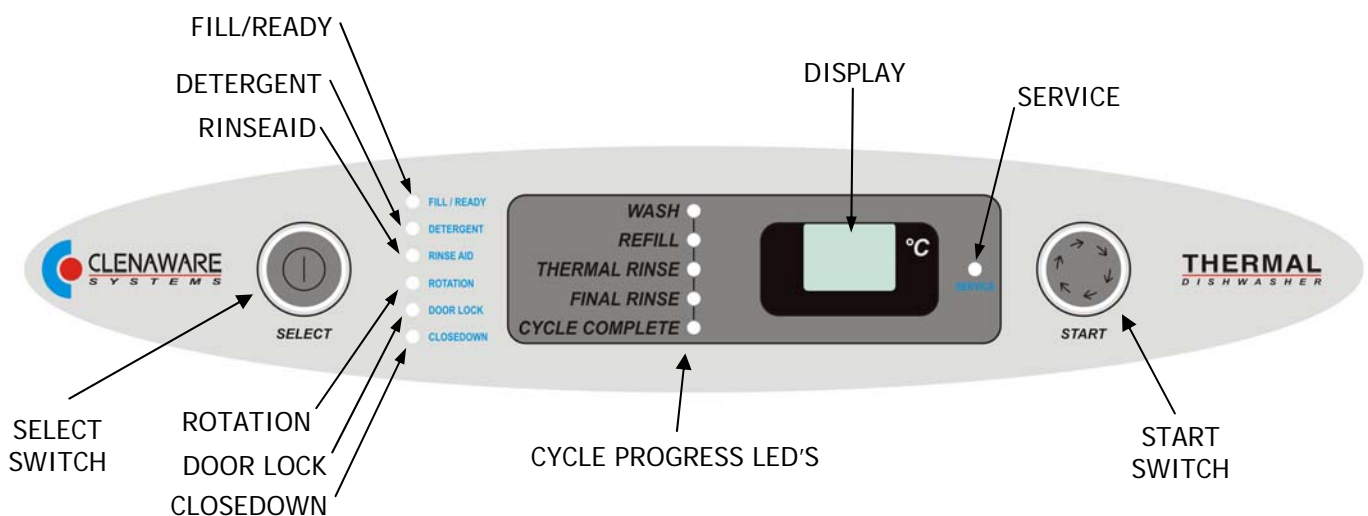

Switch the Machine On

- Press the (I) SELECT Switch: The Select Switch will be illuminated blue.



Filling

- When the machine is switched on, a fill heat sequence will be performed as follows:
 - The rinse tank will fill with water.
 - The drain pump will operate to vacate any water from the wash tank.
 - The Fill/Ready Lamp will be illuminated orange.
 - The Start Switch will be illuminated green (rotating).
- Once the rinse tank is full, the water will be heated to 82°C.
- The Fill/Ready Lamp will flash orange during heating.
- Once up to temperature, the rinse water will be pumped into the wash tank.
- After the Fill/Heat sequence has been completed, the audible alarm will bleep five times.
- The Fill/Ready Lamp and Start switch will be illuminated green.
- "TD" will be displayed.
- The rinse tank will re-fill and heat to standby temperature.

The machine will now be in **STANDBY MODE**, ready to operate wash cycles.

Note:

If the machine has not been switched off using the **CLOSEDOWN** Cycle (or suffered a power failure) a short refreshment cycle will be performed at start-up to ensure that all water is vacated from the machine. The Fill/Ready Lamp being illuminated red indicates this.

To avoid this, and to ensure hygienic conditions, **ALWAYS** use the **CLOSEDOWN** cycle at the end of a session.



Washing

- The TD50 incorporates two possible temperature/time regimes for thermal disinfection:
 - 82°C for 2 minutes (default)
 - 72°C for 3 minutes
- The '72°C for 3 minute' thermal disinfection can be selected by an engineer upon request.
- The TD cycle consists of the following functions:
 - Re-circulating wash period with detergent.
 - Refill period, replacing the wash tank water.
 - Thermal Rinse period, raising the rinse water to TD temperature and holding for the TD time.
 - Final Cooling Rinse.

Starting a Wash Cycle

- Fill the rack with crockery etc to be washed having first removed any liquid or solid waste elsewhere. Pre-rinsing is recommended. Open the door and slide the rack into position. Close the door.
- Press the START Switch to begin the cycle:
 - The Start Switch will be illuminated green (rotating).
 - The 'WASH' progress indicator lamp will be lit.
 - The wash pump will be energised for the initial two minutes of the cycle, re-circulating the wash water via the rotating spraybars.

The door must not be opened during the wash cycle.

- During the wash period the rinse water will be heated to the correct operating temperature.

If the rinse water is not up to temperature at the end of the wash period, the machine will continue washing until the correct temperature is reached.



- At the end of the wash period, the wash pump will de-energise.
- The 'REFILL' progress indicator lamp will be lit.
- The Door will be locked, indicated by the Door Lock lamp illuminated orange.

Note: The Door Lock is an optional fit on the TD50.
- The wash water will be emptied and replaced with pre-heated fresh water.
- Following this, the 'THERMAL RINSE' progress indicator lamp will be lit.
- During Thermal Rinse, the TD rinse water will be re-circulated via the spraybars.
- The TD rinse water will be heated to 82°C (or 72°C). The temperature is displayed.
- Once up to TD temperature, this temperature will be held for the 2 minute (or 3 minute) TD period. The temperature will flash in the display during the TD period.
- Following this, the 'FINAL RINSE' progress indicator lamp will be lit.
- The Door will be unlocked, indicated by the Door Lock lamp illuminated green.
Note: The Door Lock is an optional fit on the TD50.
- The cycle will conclude with a short drain and cooling rinse sequence.
- At the end of the cycle, the audible alarm will bleep five times.
- 'TD' will flash in the display.
- Open the door and remove the rack. Close the door.
- The Fill/Ready Lamp and Start switch will be illuminated green.
- The rinse tank will re-fill and heat to standby temperature.
- The machine will be in Standby, ready for another wash cycle to be started.



Close Down Cycle

- The machine can be closed down at any time by pressing the SELECT Switch (the Closedown Lamp will flash green), followed by the START Switch. This will force a Closedown Cycle.
- The Start Switch will be illuminated green (rotating).
- The drain pump will be energised during the entire cycle, removing water from the wash tank.

The door must not be opened during the closedown cycle.

- The rinse pump will be energised for the initial 20 seconds of the cycle to remove the water from the rinse tank.
- At the end of the 40 second cycle, the machine will switch off, with the Select Switch illuminated red.
- Isolate the water and electrical supplies to the machine.



Chemical Injection and Warnings

Detergent & Rinse-Aid

Detergent and Rinse-Aid is automatically injected during each washing cycle. The amount of chemical injected is dependent on site conditions, and can be adjusted by an engineer. The default setting is 300:1 for detergent and 3000:1 for rinse-aid. A bottle of rinse-aid will last 10 times longer (before replacement is required) than detergent.



Detergent and Rinseaid is continuously monitored (by conductivity) on entry into the machine.

If a chemical is detected then the relevant lamp is illuminated green.

If not detected, then the lamp is illuminated orange.

Note: In some cases, poor quality chemicals may not be detected.

If a chemical is low (orange warning lamp), then replace the relevant bottle.

For rinse-aid low, it is recommended to restart the machine to allow the rinse-aid to prime.

It is important that the correct chemical suction tube (colour coded) is connected to the correct chemical.

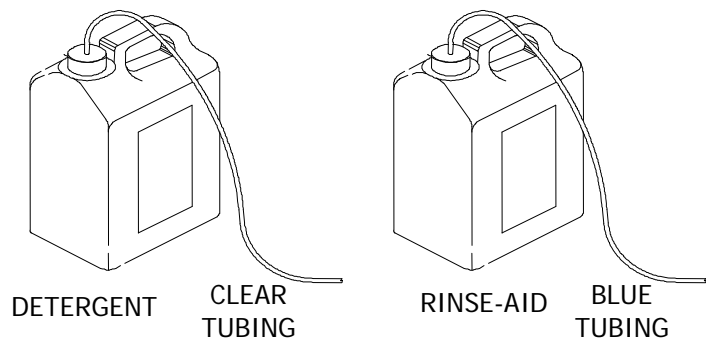

**OPERATING THE MACHINE WITHOUT THE CORRECT CHEMICALS,
OR WITH CHEMICAL TUBES WRONGLY CONNECTED TO BOTTLES
WILL DAMAGE THE WARE AND PROMOTE SCALE BUILD-UP**



Spraybar Rotation Warning

Poor wash quality will result from the lack of rotation of the spray-bar. The machine incorporates a spray-bar rotation sensor and will highlight a problem by use of a warning lamp.



Spray bar rotation is continually monitored during the wash and rinse periods of a wash cycle.

If rotation is detected: The warning lamp will be illuminated green

If rotation not detected: The warning lamp will be illuminated red at the end of the cycle.

The reason for lack of rotation will normally be caused by soil build-up around the top and bottom wash arm bearings, blocked filters, or by blocked jets.

Remove both spray-bar assemblies & filters and clean thoroughly. Refit the parts. The top and bottom spray-bars should rotate freely. Check that the warning lamp responds to the rotations.



CLEAN THE MACHINE THOROUGHLY THEN START A WASH CYCLE

ONLY CALL AN ENGINEER IF THE ERROR CANNOT BE CLEARED



Other Features

Energy Saving

In Standby Mode the rinse water temperature is held at a lower value than that required for the cycle rinse. The shortfall in rinse temperature is made up during the wash part of a cycle. In this way, energy is not needlessly wasted.

Data Fault

If for any reason the data within the control system becomes corrupted, this will be indicated on the control panel with all indicator lamps flashing.

To re-load the default data, press the START Switch.

If the problem persists, call an engineer.



Daily Maintenance

IMPORTANT!

Ensure that the electrical and water supplies are switched off while carrying out the following procedures. This appliance must not be cleaned with a water jet.

Refer to Exploded Diagram below for help with maintenance and spares.

- At the end of each session, open the machine door and remove any racks.
- Remove the top and bottom Wash Arms by unscrewing their central retaining fasteners and lifting away. Ensure that the mating surfaces around the spindle areas are clear of debris.

Inspect the spray-jet nozzles for blockages.

- To clean blocked jets, the affected nozzle can be sprung-off from the spray-bar and flushed clear with running water.

Do not dismantle the spray-arms from the Hub.

- Ensure that all the spray-jets are seated firmly on the spray-bar, and that all the jets have an o-ring attached. Note that the white wash spray-jets are a different size to the blue rinse-jets, so it is impossible to fit incorrectly.
- Damaged or missing spray-jets and o-rings must be replaced for efficient operation of the machine.
- Carefully remove any debris from the machine interior (protective gloves are recommended).
- Clean all internal surfaces of the wash tank with a nylon brush and wipe with a clean damp cloth. Pay particular attention to the door labyrinths and hinge areas.

Do not use a wire brush for cleaning.



- Remove the Main Tray Filter which covers the wash tank trough, and the Drum Filter which covers the wash outlet hole. Brush them clean under running water to ensure that all particles and fibres are removed.
- Use a damp cloth to wipe clean the wash tank trough.
- Unscrew and remove the two Flat Disc Filters and brush clean under running water.
- Re-assemble the fittings in reverse order, ensuring that all four filters are in their correct positions, and that both spray-bars rotate freely. Do not over tighten spray-bar fixing screws – finger tight is sufficient.
- Check and if necessary replace the Detergent and Rinse-aid containers.
- The regular use of Renovate Powder as a Machine Cleaner is recommended.

Vital Parts to Be Regularly Cleaned / Maintained

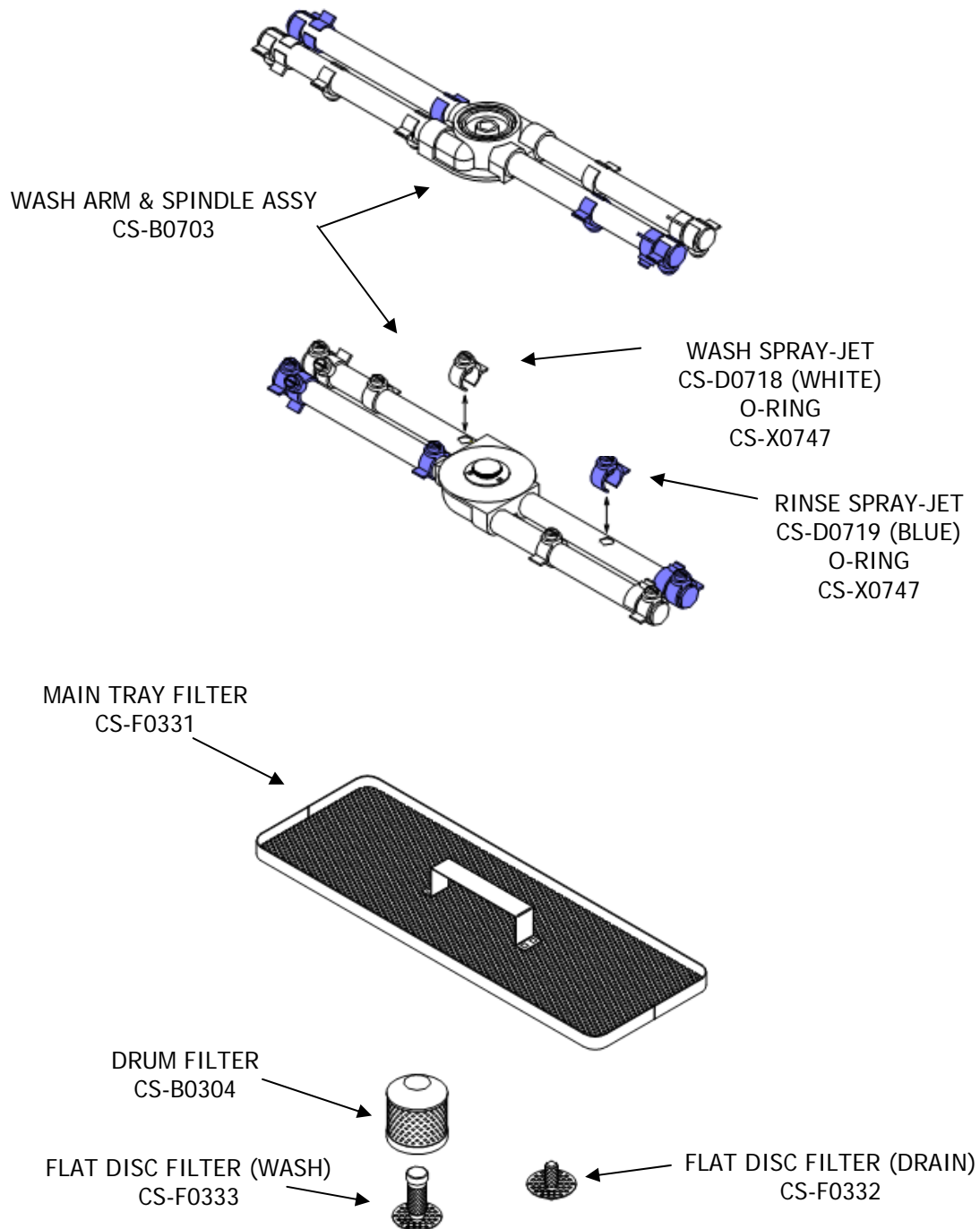



Caring For Your Dish Washer

Observance of the following will ensure maximum efficiency from your machine:

Please **“do”** the following:

Preparation

- Remove all solid material from dishes etc by scraping and pre-rinsing.
- Ensure that all drink residues are disposed of, prior to washing.

Racking and Stacking

- Ensure that racks are loaded with even distribution, and that cups and glasses are inverted.
- Use open racks for cups and spiked racks for dishes.
- Use a cutlery rack placed in an open rack. Cutlery should be loaded with handles facing down.
- Be aware of the weight of a fully loaded rack.

Machine Preparation and Use

- Ensure that the machine interior is thoroughly clean and free of debris.
- Remove and thoroughly clean all jets, filters, wash arms etc. DAILY. Wash filters must be absolutely clean and located correctly for the machine to operate efficiently.
- Ensure that the Jets are located correctly and check that both Spray Bars are free to rotate.
- Ensure that the detergent and rinse aid containers are sufficiently full for the anticipated use during the session. Use only quality detergents and rinse aids that are designed for dishwashing.
- Ensure that a Water Softener, where fitted, is regenerated regularly.



- Ensure that the Fill/Ready Lamp is green before starting a cycle.
- Ensure that a wash cycle is fully completed before removal of rack. On completion of a cycle, the Start Switch will stop rotating, and there will be five bleeps by the audible alarm.
- Operate a Closedown Cycle to drain the machine completely after every trading session.
- Leave the door open at the end of session to ventilate the machine.

Please **“do not”** do the following:

- Attempt to wash more than one rack per wash cycle.
- Interrupt the cycle and attempt to remove the rack before the Wash Cycle is completed.
- Wash with water only. Detergent and Rinse Aid must be used.
- Stack cups or glasses on top of each other, or overload the rack.
- Leave washed items in the machine.
- Handle crockery, glasses, or cutlery during the drying period. Allow to dry naturally before handling.
- Leave the door open between cycles.
- Isolate power without operating a Closedown Cycle.
- **Attempt to remove machine covers.**



Simple Fault Finding

Should a problem develop with your TD50 machine, please consult the following fault-finding procedures before calling for assistance.

Service Lamp Flashes

- The TD50 machine is designed to keep operating regardless of most functional errors that might occur. For example, for an internal heater failure, the machine will still operate, but with no internal heating.
- In most cases, the machine will resolve the fault, but for some errors the machine will be inoperative.

If you experience continued error flashes on the service lamp, or if the machine stalls, isolate the electrical supply for 10 seconds, re-connect and attempt to re-start the machine.

- If the problem persists, call for assistance.

Machine will not switch on

- Check the power supply is switched on.
- Isolate the electrical supply for 10 seconds, re-connect and attempt to re-start the machine.
- Check for operation of circuit breakers or fuses in distribution box.
- Call for assistance.



Machine does not fill

This fault usually generates a warning on the control panel.

The Service Lamp will flash with the frequency of 3 flashes and 1 pause and E3 will be displayed.

- Check that the water supply is switched on, and that a water supply is available.
- Check that the Inlet Hose is not kinked.
- If a Water Softener is fitted, check that the softener is not regenerating.
- Call for assistance.

Machine will not drain

- Check for blocked drain filter.
- Call for assistance.

Machine filled Okay, but wash tank is empty

- Check for water siphoning out of the machine due to the Drain Outlet Hose being pushed too far down the waste up-stand.
- Call for assistance.

Machine will not Operate a Wash Cycle

- Check that the Fill/Ready Lamp is lit 'green', and that the door is closed.
- Call for assistance

Washed items remain soiled

- Ensure that excessive soiling is removed before the washing process by scraping and/or pre-rinsing.
- Stubborn or baked-on soil may require pre-soaking prior to the washing process.



- Check that the Rotation lamp on the control panel is lit 'green'. If lit 'red', check that both Spray-Bars rotate freely, and that no Spray-Jets are blocked or missing.
- Check that the Detergent and Rinse-Aid lamps on the control panel are lit 'green'. If lit 'amber', replace the relevant chemical.
- Check that chemical suction tubes are correctly in position in the containers. The 'clear' tube should be fed by the detergent container, and the 'blue' tube fed by the Rinse-Aid container.
- Ensure that quality chemicals designed for dishwashing are in use.
- Check that the water softener (where fitted) is being regenerated with granular salt at frequent intervals.
- Call for assistance.

Washed items not Shedding ("Spotty" in appearance)

- Ensure that the wash cycle has completed before removing the rack of washed items from the machine.
- Check that the Detergent and Rinse-Aid lamps on the control panel are lit 'green'. If lit 'amber', replace the relevant chemical.
- Check that chemical suction tubes are correctly in position in the containers. The 'clear' tube should be fed by the detergent container, and the 'blue' tube fed by the Rinse-Aid container.
- Ensure that quality chemicals designed for dishwashing are in use.
- Check that the Rotation lamp on the control panel is lit 'green'. If lit 'red', check that both Spray-Bars rotate freely, and that no Spray-Jets are blocked or missing.
- Check that the water softener (where fitted) is being regenerated with granular salt at frequent intervals.
- Call for assistance.



Washed items "Smearly" or "Greasy" in appearance

- Check that the Detergent and Rinse-Aid lamps on the control panel are lit 'green'. If lit 'amber', replace the relevant chemical.
- Check that chemical suction tubes are correctly in position in the containers. The 'clear' tube should be fed by the detergent container, and the 'blue' tube fed by the Rinse-Aid container.
- Ensure that quality chemicals designed for dishwashing are in use.
- Check that the Rotation lamp on the control panel is lit 'green'. If lit 'red', check that both Spray-Bars rotate freely, and Spray-Jets are clear and in position.
- Ensure all wash filters for blockages and ensure they are correctly positioned.
- Call for assistance.

Machine noisy in Wash Cycle

- Check that the wash tank filter has been fitted properly.
- Check that there is water in the wash tank.
- Check the wash tank filters for blockages.
- Call for assistance.

Excessive foam in Cabinet

- Ensure that quality chemicals designed for glass washing are in use.
- Check that chemical suction tubes are correctly in position in the containers. The 'clear' tube should be fed by the detergent container, and the 'blue' tube fed by the Rinse-Aid container.
- Ensure that the wash filters are in position in the wash tank.
- Call for assistance.



Scale Build-up in machine

- Check that the water softener (where fitted) is being regenerated with granular salt at frequent intervals.
- If the machine is connected to a hard water supply, chemicals designed for hard water, a Water Softener, or Filter should be considered.

Machine Errors

If the machine experiences a major error, this is indicated by the Service Lamp flashing red.

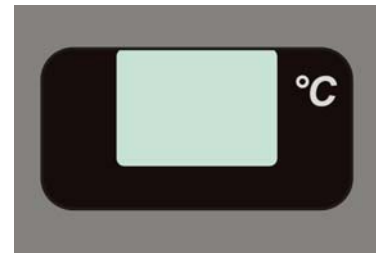

Description of errors:

Overfill Error (code '1')

- The Service Lamp will flash at a rate of – 1 Flash and 1 Pause
- The machine will be unusable.
- Closedown the machine and call for an engineer.

Overfill Error (code '2')

- The Service Lamp will flash at a rate of – 2 Flashes and 1 Pause
- The machine will be unusable.
- Closedown the machine and call for an engineer.

Fill Error (code '3')

- The Service Lamp will flash at a rate of – 3 Flashes and 1 Pause
- Machine stalls, but will resume if water supply is restored.
- Check water supply. If problem persists Closedown the machine and call for an engineer.



Refill Error (code '4')

- The Service Lamp will flash at a rate of – 4 Flashes and 1 Pause
- The machine will be unusable.
- Closedown the machine and call for an engineer.

Rinse Timeout Error (code '5')

- The Service Lamp will flash at a rate of – 5 Flashes and 1 Pause
- The machine will be unusable.
- Closedown the machine. Check and clean the rinse jets, and restart the machine.
- If problem persists, call for an engineer.

Heating Error (code '6')

- The Service Lamp will flash at a rate of – 6 Flashes and 1 Pause.
- The machine will still be usable, but with limited internal water heating.
- If problem persists, call for an engineer.

Temperature Sensing Error (code '7')

- The Service Lamp will flash at a rate of – 7 Flashes and 1 Pause.
- The machine will still be usable, but with limited internal water heating.
- If problem persists, call for an engineer.



Temperature Sensing Error (code '8')

- The Service Lamp will flash at a rate of – 8 Flashes and 1 Pause.
- The machine will still be usable, but with limited internal water heating.
- If problem persists, call for an engineer.

Wash Tank Water Level Error (code '9')

- The Service Lamp will flash at a rate of – 9 Flashes and 1 Pause.
- Restart the machine to reset the water level sensors.
- If problem persists, call for an engineer.

Note: To Closedown the machine, press the **SELECT** Switch, followed by the **START** Switch.



Dish Washer Installation

Siting

The machine must be sited on a sound level surface, with adequate clearance for servicing. Allow 50mm extra width and height. Be sure to provide allowance for water, drain, and electrical connections, and for the positioning of two 5lt Chemical Bottles.

Electrical Connection

Electrical connection must be carried out by a competent electrical engineer

This class 1 appliance and must be earthed

The following instructions must be followed before connecting to the electrical supply.

- Check that the supply voltage is within the range marked on the appliance rating plate.
- The use of a Residual Current Device is recommended.
- The power supply cord must be oil resistant, sheathed flexible cable not lighter than ordinary polychloroprene or other equivalent synthetic elastomer-sheathed cord (code HO7 RN-F).

Single Phase Operation

The wires in the mains lead supplied are coloured in accordance with the following code:

Green/Yellow	-	Earth
Blue	-	Neutral
Brown	-	Live

As the colours of the wires in the mains lead of this appliance may not correspond with the colour markings on your supply terminals, proceed as follows:

- The wire, which is coloured green and yellow, must be connected to the terminal marked "E" or by the earth symbol \equiv , or coloured green or green and yellow.
- The wire, which is coloured blue, must be connected to the terminal marked "N" or, coloured black.
- The wire, which is coloured brown, must be connected to the terminal marked "L" or, coloured red.



Connect to the electrical supply via a double pole-isolating device incorporated in the fixed wiring with contact separation of at least 3mm located within one metre of the machine so that the switch is in an easily accessible position. If in doubt, consult a qualified electrician.

30 Amp Operation (As Supplied)

Machines are supplied from the factory internally wired for 30 amp (5.5 kW) operation and fitted with a 4mm² Mains Cable. Connection must be made to a 230 – 240V 50Hz 30 amp supply. Fuse @ 25 Amps.

13 Amp Operation (Optional on a Single Phase machine)

Machines can be de-rated for operation on a 13 Amp supply by a competent engineer. This modification requires a change in mains cable type, and internal wiring changes as described behind the machines bottom front cover.

Connection must be made to a 230 – 240V 50Hz 13 amp supply. Fuse @ 13 Amps.

Three Phase Machine

A three phase machine must only be connected to a 3-phase + N electrical supply and cannot be de-rated to single phase operation.

The wires of the 5-core 2.5mm² mains lead supplied are coloured in accordance with the following code:

Green/Yellow	-	Earth
Blue	-	Neutral
Brown	-	Live Phase 1
Black	-	Live Phase 2
Black	-	Live Phase 3

As the colours of the wires in the mains lead of this appliance may not correspond with the colour markings on your supply terminals, proceed as follows:

- The wire, which is coloured green and yellow, must be connected to the terminal marked "E" or by the earth symbol \equiv , or coloured green or green and yellow.
- The wire coloured blue, must be connected to the terminal marked "N".
- The wire coloured brown, must be connected to the terminal marked "L1".
- The wire coloured black, must be connected to the terminal marked "L2".
- The 2nd wire coloured black, must be connected to the terminal marked "L3".
- Connection **must** be made to a 415v + N 50Hz supply. Fuse @ 15 Amps/Phase.



Connect to the electrical supply via an all-pole isolating device incorporated in the fixed wiring with contact separation of at least 3mm located within one metre of the machine so that the switch is in an easily accessible position. If in doubt, consult a qualified electrician.

Equipotential Bonding

This appliance is provided with a dedicated external terminal located on the lower rear cross member to facilitate the connection of an equipotential bonding conductor and is marked with the following symbol:-

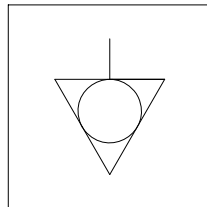

Electrical Ratings

Single Phase 30A (As Supplied)

Voltage	230 - 240 V \sim 50Hz
Input	5.5 kW
Current	23 Amps

Single Phase 13A (De-Rated option on single phase machine)

Voltage	230 - 240 V \sim 50Hz
Input	3 kW
Current	13 Amps

Three Phase

Voltage	415 V \sim 50Hz
Input	8 kW
Current	12 Amps/Phase



Water Connection

The TD50 50 incorporates an integral Break Tank that has a Type 'A' Airgap that complies with the requirements of WRC IRN 001. The machine can be connected to storage, or direct to Mains Water Supply.

The machine incorporates an integral pumped rinse system, therefore external booster pumps are not required and should not be connected.

The machine has two water inlet solenoids, marked red for Hot and blue for Cold.

For optimum performance, the machine should be connected to a **Hot** and **Cold** water supply. The hot water supply is used for normal filling, keeping cycle times to a minimum. The cold water supply is used for the final (cooling) rinse.

If the installation has only one supply, then both inlet solenoids must be connected to the single supply using a 'Y' piece.

- Cold 50– 1000 kPa (0.5-10 bar) @ 5 litres/min (minimum)
- Hot 50 – 150 kPa (0.5-1.5 bar) @ 5 litres/min (minimum)
- Maximum hot water supply temperature 60°C

Connection is by flexible hoses, which terminate with $\frac{3}{4}$ " BSP female fittings. Supplies must be terminated with $\frac{3}{4}$ " BSP male threaded taps for machine isolation, and positioned within one metre of the machine.

Water Softeners

The Hot and cold water supplies must not exceed 120mg/l calcium carbonate (CaCO₃) equivalent to 8 degrees Clarke or the use of a water softener will be required.

Most hospitals and healthcare environments operate with a softened hot supply and an un-softened cold (potable) supply.

Where the hot supply is non-softened the use of a hot auto softener is recommended.

Two methods of connection are recommended:

- The Cold supply via a softener to the machine, and the Hot supply direct from main to machine.
- Hot supply connected direct to hot and cold valve on machine using Y piece. (This method may lead to a higher wash temperature due to an increase in the final rinse temperature during periods of continuous use).

Examples

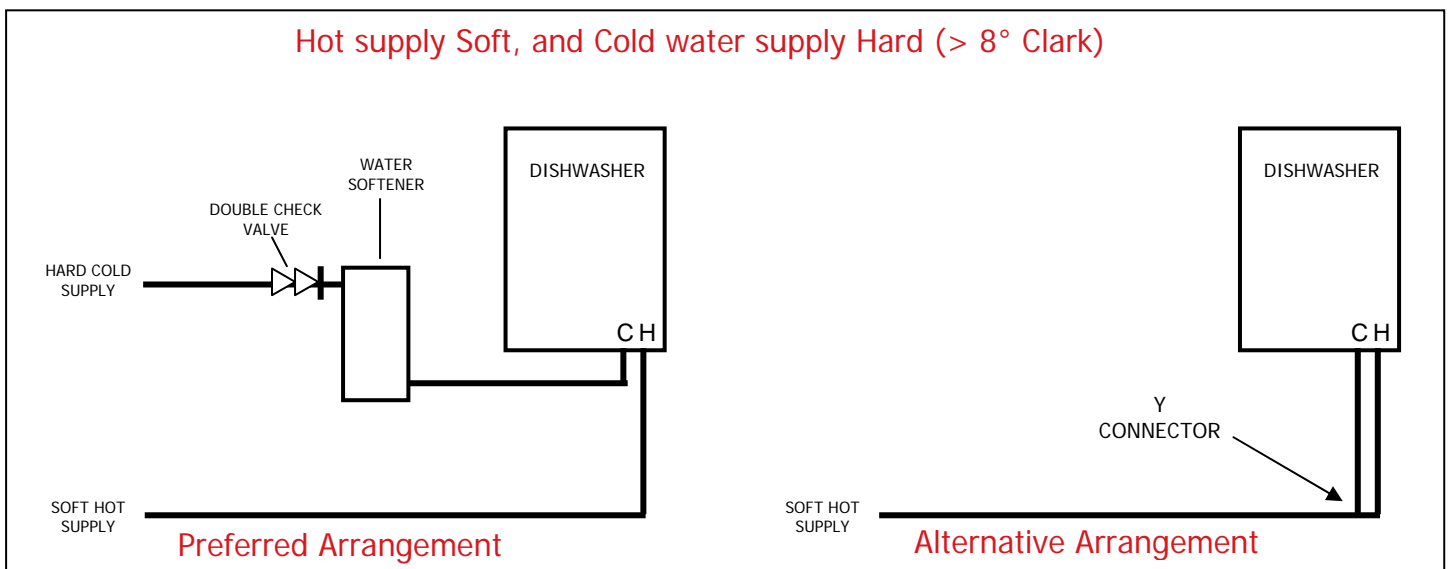
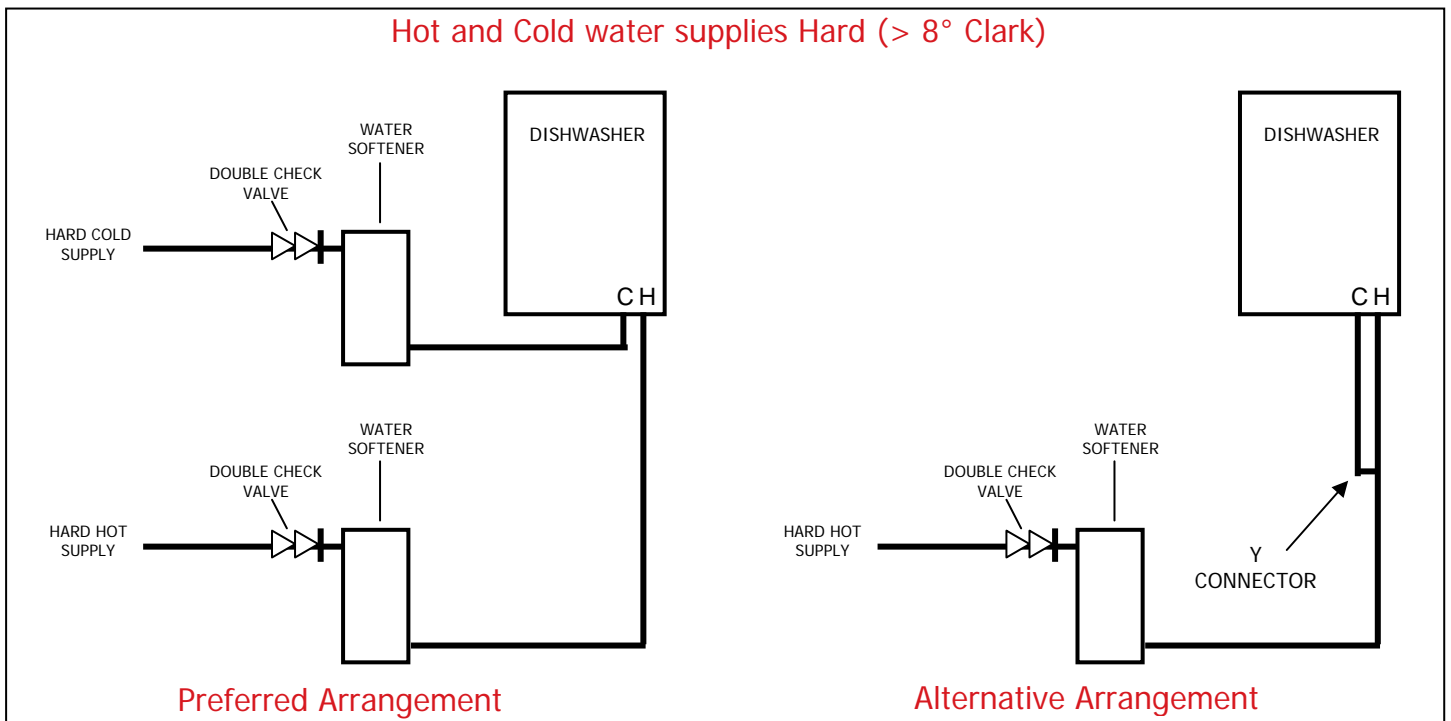



Drain Connection

This machine has a pumped waste system and requires a trapped 1½" open vent upstand with the top 450mm from the base of the machine. Place non-kink hose and former into upstand.

Detergent and Rinse Aid Connection

Injection is automatic. The end of the suction hoses (clear for detergent and blue for rinse aid) should be fitted with the supplied caps, weights and filters and placed into the base of the relevant containers.

Model	TD 50 Mk5		
Part No	CS-A0037		CS-A0038
Electrical Connection	13 Amp	30 Amp	3 Phase
Rack Size	500mm		
Height Clearance	280mm		
TD Disinfecting Time/Temp	2 min @ 82°C or 3 mins @ 72°C		
Water Used/Cycle	10 lt's		
Supply Voltage	230 - 240V (1) 50Hz		415V (3+N) 50Hz
Power Input	3 kW	5.5 kW	8 kW
Fuse @	13 Amp	25 Amp	15 Amp/Phase
Rinse Heater Power	2.5 kW	5 kW	7.5 kW
Wash Pump Power	300W		
Wash Tank Capacity	6½ lt's		
Pre-Wash Temperature	60°C		
Rinse Pump Power	300W		
Rinse Tank Capacity	6½ lt's		
Rinse Tank Temperature	80°C		
Water Pressure/Flow - Hot	0.5–1.5 Bar @ 5lt/min (60°C max)		
Water Pressure/Flow - Cold	0.5–10 Bar @ 5lt/min (5°C min)		
Waste	Pumped + Empty Cycle		
Rinse-Aid Dosing	Adjustable Peristaltic Pump		
Detergent Dosing	Adjustable Peristaltic Pump		
Operating Weight	92 Kg		
Shipping Weight	86 Kg		

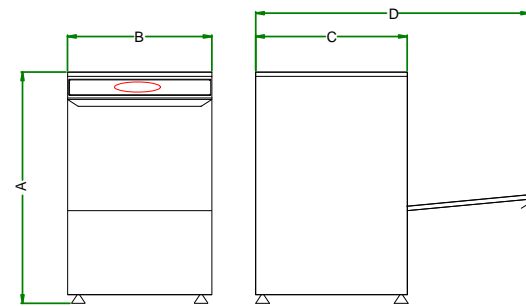

	A	B	C	D
TD50	840	605	650	1000

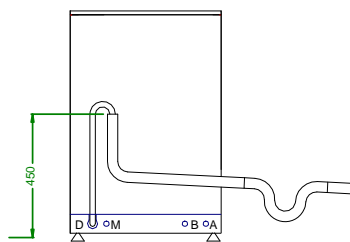

↑
A = Hot B = Cold D = Drain M = Electric

Clenaware Systems Ltd reserve the right to amend specifications

WEEE

This equipment contains electrical and electronic components.

At the end of its life, this equipment should not be mixed with general waste during disposal.

For proper treatment, recovery and recycling, please take this equipment to a designated recycling facility. Please contact your local authority for further details of your nearest designated recycling facility.

Alternatively, you can contact your supplier of the equivalent new product to arrange disposal.

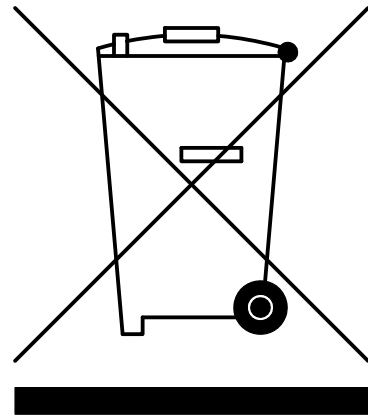



Service and Warranty

Warranty

All Clenaware Systems machines are covered by a 12 month guarantee.

Clenaware Systems Ltd guarantee that any and all products manufactured and marketed under the Clenaware Systems name and used in the correct way are free from defects in material and/or workmanship for a period of 12 months from the date of first installation.

All repairs will be carried out Monday to Friday and between the hours of 9.00 and 17.30.

The Clenaware Systems warranty covers any material or manufacturing and we will repair or replace any defect provided that:

- 1: Installation and commissioning was carried out by Clenaware Systems or an approved / nominated agent in accordance with the Clenaware Systems requirements as detailed in the user manual.
- 2: Products and/or components are not modified, altered or dismantled by unauthorised persons.
- 3: Products are maintained in accordance with the Clenaware Systems requirements by Clenaware Systems or an approved / nominated agent.
- 4: Products are cleaned and preventative maintenance carried out in accordance with the Clenaware Systems requirements as detailed in the owner's manual and on the care card.
- 5: Warranty service is performed by Clenaware Systems or an approved / nominated agent using genuine Clenaware Systems replacement parts supplied by Clenaware Systems or an approved / nominated agent.



- 6: A maintenance service has been carried out by Clenaware Systems or an approved / nominated agent at 12 months from purchase/installation. This is chargeable to the customer.
- 7: That chemicals used during normal operating are those recommended and purchased from Clenaware Systems or an approved / nominated agent.

The Clenaware Systems warranty will not cover the following:

- 1: Failure or damage caused by misuse, accidental or malicious damage.
- 2: Failure or damage caused by the loss of or fluctuations in electrical power supply.
- 3: Failure or damage caused by water supply failure or any other plumbing or drainage problem. This includes any water treatment device connected to the product.
- 4: Labour and material costs associated with cleaning and preventative maintenance as detailed in the owners manual or failure to perform a 12 month service.
- 5: Labour and material costs associated with replacing filters or other water treatment devices.
- 6: Labour and material costs where non recommended chemicals are used causing failure due to corrosion, loss of beer-head retention, taste, appearance, cleanliness of washed glassware, or the formation of lime scale within the machine.
- 7: Labour and material costs associated with failure or operating problems caused by incorrect installation.
- 8: Any consequential loss as a result of product failure.
- 9: No fault found calls; these will be chargeable to the customer.
- 10: Costs associated with repairs requested out of hours i.e. before 09.00 hours and after 17.30 hours, Monday to Friday, all day Saturday, Sunday and Public Holidays.



Service

Warranty

- 1: All warranty service is performed by Clenaware Systems or an approved / nominated agent.
- 2: Warranty service is performed Monday to Friday and between the hours of 09.00 and 17.30.
- 3: All warranty claims should be logged by calling: **01933 666244**

Please have the following details to hand to speed up the processing of your call:

- a) Machine Serial Number
- b) Site Name
- c) Contact Name & Telephone Number
- d) Access Times
- e) Description of problem

When calling please try to avoid "Out Of Order", "It's Faulty" or "Not Washing Correctly" as the "Description of problem".

Maintenance & Servicing

- 1: A number of different types of service contract are available through Clenaware Systems or an approved / nominated agent.
- 2: All enquiries should be logged by calling: **01933 666244**
- 3: For further information or clarification on warranty and service please contact Clenaware Systems using the details on the last page of this document.



Disclaimer

- 1: Installation and commissioning of the Clenaware Systems machines should be carried out by Clenaware Systems or an approved / nominated agent in accordance with the Clenaware Systems requirements as detailed in the user manual. Failure to install and commission a machine in line with these requirements can invalidate the warranty.
- 2: As part of a process of ongoing innovation and brand development, Clenaware Systems reserves the right to change specifications without prior notice.
- 3: Brand Names, Trade Marks, Trade Names, Images and Drawings used in any documents relating to a Clenaware Systems product are for reference purposes only and should not be reproduced without the written permission of Clenaware Systems Ltd.



CLENARE SYSTEMS LTD

Main Office : +44 (0) 1933 666244

Fax: +44 (0) 1933 665 584

Web: www.clenaware.co.uk

Email: info@clenaware.co.uk



Main Office Address

The Wagon Hovel
Strixton Manor Business Centre
Strixton. Wellingborough
Northants. NN29 7PA

Factory Address

30 Huxley Close
Park Farm Industrial Estate
Wellingborough
Northants. NN8 6AB