



Owner's Manual



Sovereign Mark 5

Glass Washing Machine



WEE/DE2076RU

Machines are manufactured to ISO 9001 : 2008





Index

Sovereign Glass Washer Operating Instructions.....	3
Preparation	3
Filling	4
Standby Mode	5
Washing Glass and Plastic	6
Renovate Cycle	7
Closedown Cycle	8
Chemical Injection and Warnings	9
Spraybar Rotation Warning.....	10
Other Features	11
Daily Maintenance.....	12
Vital Parts To Be Regularly Cleaned / Maintained.....	14
Caring For Your Sovereign Glass Washer	16
Simple Fault Finding.....	18
Machine Errors	23
Sovereign Glass Washer Installation	25
WEEE	30
Service And Warranty.....	31
Warranty	31
Service	33
Disclaimer	34

Sovereign Glass Washer Operating Instructions

Preparation

- Ensure that the machine interior is clean and soil-free, and that the bottom spray bar rotates freely, jets are clean and correctly located.
- Check that the upper rinse dome is in place.
- Ensure that all four filters are in position in the wash tank trough:

Primary **Flat Disc Filters** (2) are fitted to the wash and waste outlets. Secondary **Drum Filter** fitted over the wash outlet (rear outlet). Main **Tray Filter** that encloses the wash tank trough.

- Check that the detergent and rinse aid containers have sufficient liquid level and that the suction tubes are in their appropriate products. **Blue Tube** for rinse aid, and **Clear Tube** for detergent.
- Switch on the water and electrical supplies to the machine. Close the door.

The Select Switch will be illuminated red.

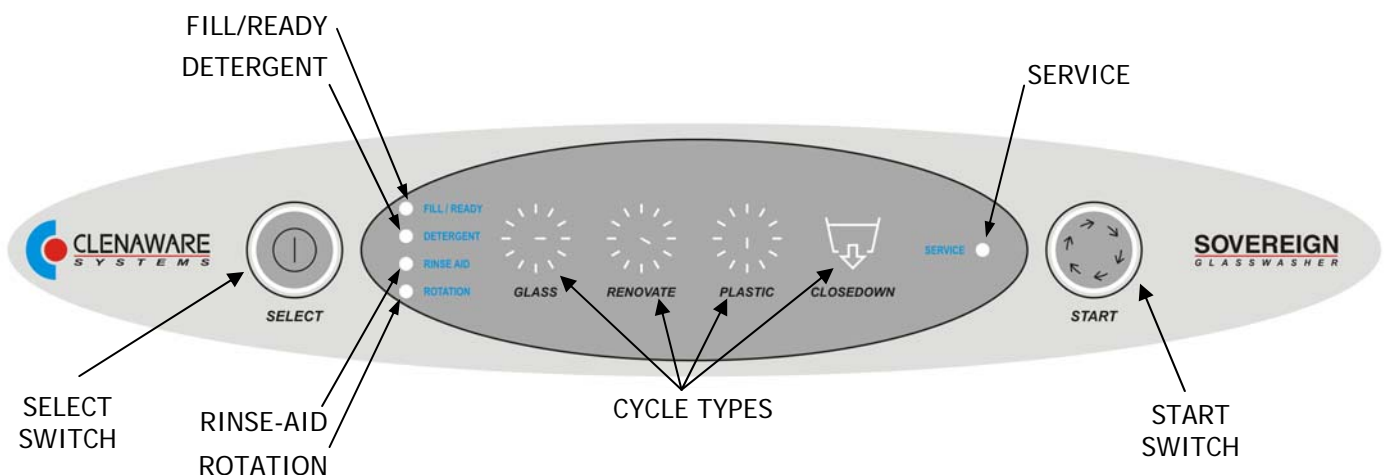

Switch The Machine On

- Press the (I) SELECT Switch: The Select Switch will be illuminated blue.



Filling

- When the machine is switched on, a fill heat sequence will be performed as follows:
 - The rinse tank will fill with water.
 - The drain pump will operate to vacate any water from the wash tank.
 - The Fill/Ready Lamp will be illuminated orange.
 - The Start Switch will be illuminated green (rotating).
- Once the rinse tank is full, the water will be heated to 75°C.
- The Fill/Ready Lamp will flash orange during heating.
- Once up to temperature, the rinse water will be pumped into the wash tank.
- After the Fill/Heat sequence has been completed, the audible alarm will bleep five times.
- The Fill/Ready Lamp and Start switch will be illuminated green.
- The Glass Cycle Lamp will be illuminated blue.
- The rinse tank will re-fill and heat to standby temperature.

The machine will now be in **STANDBY MODE**, ready to operate wash cycles.

Note:

If the machine has not been switched off using the **CLOSEDOWN** Cycle (or suffered a power failure) a short refreshment cycle will be performed at start-up to ensure that all water is vacated from the machine. The Fill/Ready Lamp being illuminated red indicates this.

To avoid this, and to ensure hygienic conditions, **ALWAYS** use the **CLOSEDOWN** cycle at the end of a session.



Standby Mode

- Pressing the 'SELECT Switch' will step through the cycle options as follows:

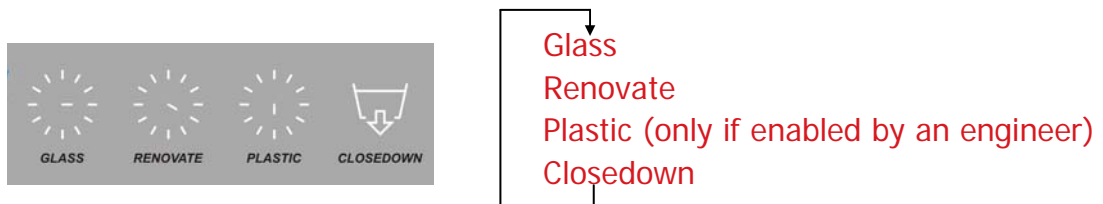

- The appropriate indicator will be illuminated blue.

GLASS CYCLE is the default cycle and used for washing normal glassware.

RENOVATE CYCLE is used in conjunction with Renovate Powder to recondition new and contaminated glassware.

PLASTIC CYCLE (if enabled) is used for washing plastic (polycarbonate etc) drinking vessels. Due to higher temperatures and chemical usage, this cycle is NOT suitable for washing normal glassware.

CLOSEDOWN CYCLE is used at the end of a washing session to empty all tanks and flush the system clean.



Washing Glass and Plastic

Note that the Glass and Plastic cycles are very similar in operation. The differences are a higher rinse temperature and increased rinse-aid dose on the plastic cycle.

- Fill a basket with inverted glasses having first emptied out any liquid or solid waste elsewhere. Open the door and slide the basket into position. Close the door.

Starting The Cycle

- Select the cycle (Glass or Plastic) required and press the START Switch to start the chosen cycle:
 - The Start Switch will be illuminated green (rotating).
 - The wash pump will be energised for the initial 90 seconds of the cycle, recirculating the wash water via the rotating spraybar

The door must not be opened during the wash cycle.

- During the wash period the rinse water will be heated to the correct operating temperature.

If the rinse water is not up to temperature at the end of the 90 second wash period, the machine will continue washing until the correct temperature is reached. The Fill/Ready Lamp flashing green indicates this.

- At the end of the wash period the wash tank will be emptied for 20 seconds.
 - The cycle will conclude with a fresh water rinse (approx. 10 seconds).
 - At the end of the cycle, the audible alarm will bleep five times.
 - The Fill/Ready Lamp and Start switch will be illuminated green.
 - The Glass Cycle Lamp will be illuminated blue.
 - The rinse tank will re-fill and heat to standby temperature.
- Open the door and remove the basket of clean glasses. Close the door.

The machine will now be in Standby Mode. Note that the Glass or Plastic cycle type will remain selected. **Note:** If the wash water temperature is too low, a short refreshment cycle will be performed at the start of the cycle. The Fill/Ready Lamp will be illuminated orange to indicate this.



Renovate Cycle

This cycle is used for the preparation of new glassware, the renovating of stained or greasy glassware, and is also recommended for cleaning the machine wash tank interior.

- Open the door and add a measure of Renovate Powder to the top of the Main Filter (avoid contact with eyes, hands and face).
- Fill a basket with inverted glasses to be renovated. Open the door and slide the basket into position. Close the door.
- Select the Renovate Cycle and press the START Switch to start the cycle:
 - The wash pump will be energised for the initial 150 seconds of the cycle, recirculating the wash water via the rotating spraybar

The door must not be opened during the wash cycle.

- At the end of the wash period the wash tank will be emptied for 20 seconds, followed by a fresh water rinse (approx 10 seconds).
- The machine will then continue with a Glass Wash Cycle as described in '**Starting The Cycle**' above.
- Open the door and remove the basket of clean glasses. Close the door.

The machine will now be in Standby Mode. Note that the cycle type will revert to Glass.



Closedown Cycle

- From Standby Mode, select the Closedown Cycle and press the START Switch to start the cycle:

At any other time (during the fill/heat sequence, during a wash cycle, or whilst the machine is in an error condition), press the SELECT Switch (the Closedown Lamp will flash) and press the START Switch. This will force a Closedown Cycle.

- The Start Switch will be illuminated green (rotating).
- The drain pump will be energised during the entire cycle, removing water from the wash tank.

The door must not be opened during the closedown cycle.

- The rinse pump will be energised for the initial 20 seconds of the cycle to remove the water from the rinse tank.
- At the end of the 40 second cycle, the machine will switch off, with the Select Switch illuminated red.
- Isolate the water and electrical supplies to the machine.



Chemical Injection and Warnings

Detergent & Rinse-Aid

Detergent and Rinse-Aid is automatically injected during each washing cycle. The amount of chemical injected is dependant on site conditions, and can be adjusted by an engineer. The default setting is 300:1 for detergent and 3000:1 for rinse-aid. A bottle of rinse-aid will last 10 times longer (before replacement is required) than detergent.



Detergent and Rinseaid is continuously monitored (by conductivity) on entry into the machine.

If a chemical is detected then the relevant lamp is illuminated green.

If not detected, then the lamp is illuminated orange.

Note: In some cases, poor quality chemicals may not be detected.

If a chemical is low (orange warning lamp), then replace the relevant bottle.

For rinse-aid low, it is recommended to restart the machine to allow the rinse-aid to prime.

It is important that the correct chemical suction tube (colour coded) is connected to the correct chemical.

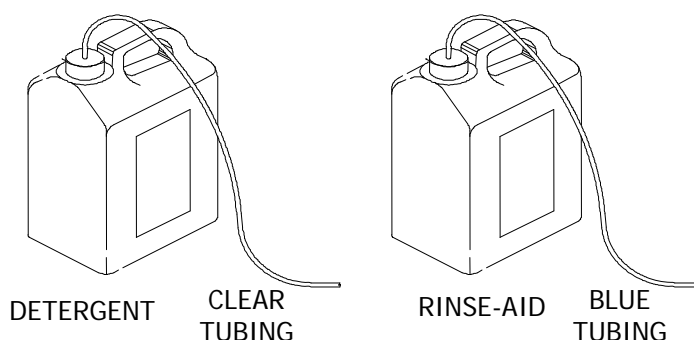

OPERATING THE MACHINE WITHOUT THE CORRECT CHEMICALS, OR WITH CHEMICAL TUBES WRONGLY CONNECTED TO BOTTLES WILL DAMAGE THE GLASSWARE AND PROMOTE SCALE BUILD-UP



Spraybar Rotation Warning

Poor wash quality will result from the lack of rotation of the spray-bar. The machine incorporates a spray-bar rotation sensor and will highlight a problem by use of a warning lamp.



Spray bar rotation is continually monitored during the wash and rinse periods of a wash cycle.

If rotation is detected: The warning lamp will be illuminated green

If rotation not detected: The warning lamp will be illuminated red
At the end of a wash cycle the lamp will flash red

The reason for lack of rotation will normally be caused by soil build-up around the wash arm bearing, blocked filters, or by blocked jets.

Remove the spray-bar assembly & filters and clean thoroughly. Refit the parts. The spray-bar should rotate freely. Check that the warning lamp responds to the rotations.



CLEAN THE MACHINE THOROUGHLY THEN START A WASH CYCLE

ONLY CALL AN ENGINEER IF THE ERROR CANNOT BE CLEARED



Other Features

Energy Saving

In Standby Mode the rinse water temperature is held at a lower value than that required for the cycle rinse. The shortfall in rinse temperature is made up during the wash part of a cycle. In this way, energy is not needlessly wasted.

The standby temperature will depend on the model, the cycle type chosen, and whether the machine is connected to 13 or 30 Amps.

Data Fault

If for any reason the data within the control system becomes corrupted, this will be indicated on the control panel with all indicator lamps flashing.

To re-load the default data, press the START Switch.

If the problem persists, call an engineer.



Daily Maintenance

IMPORTANT!

Ensure that the electrical and water supplies are switched off while carrying out the following procedures. This appliance must not be cleaned with a water jet.

Refer to Exploded Diagram below for help with maintenance and spares.

- At the end of each session, open the machine door and remove the basket.
- Remove the top Rinse Arm and bottom Wash Arm by unscrewing their central retaining fasteners and lifting away. Ensure that the mating surfaces around the spindle areas are clear of debris.

Inspect the spray-jet nozzles for blockages.

- To clean blocked jets, the affected nozzle can be sprung-off from the spray-bar and flushed clear with running water.

Do not dismantle the spray-arms from the Hub.

- Ensure that all the spray-jets are seated firmly on the spray-bar, and that all the jets have an o-ring attached. Note that the white wash spray-jets are a different size to the blue rinse-jets, so it is impossible to fit incorrectly.
- Damaged or missing spray-jets and o-rings must be replaced for efficient operation of the machine.
- Carefully remove any debris from the machine interior (protective gloves are recommended).
- Clean all internal surfaces of the wash tank with a nylon brush and wipe with a clean damp cloth. Pay particular attention to the door labyrinths and hinge areas.

Do not use a wire brush for cleaning.



- Remove the Main Tray Filter which covers the wash tank trough, and the Drum Filter which covers the wash outlet hole. Brush them clean under running water to ensure that all particles and fibres are removed.
- Use a damp cloth to wipe clean the wash tank trough.
- Unscrew and remove the two Flat Disc Filters and brush clean under running water.
- Re-assemble the fittings in reverse order, ensuring that all four filters are in their correct positions, and that both spray-bars rotate freely. Do not over tighten spray-bar fixing screws – finger tight is sufficient.
- Check and if necessary replace the Detergent and Rinse-aid containers.
- The regular use of Renovate Powder as a Machine Cleaner is recommended.

Vital Parts To Be Regularly Cleaned / Maintained

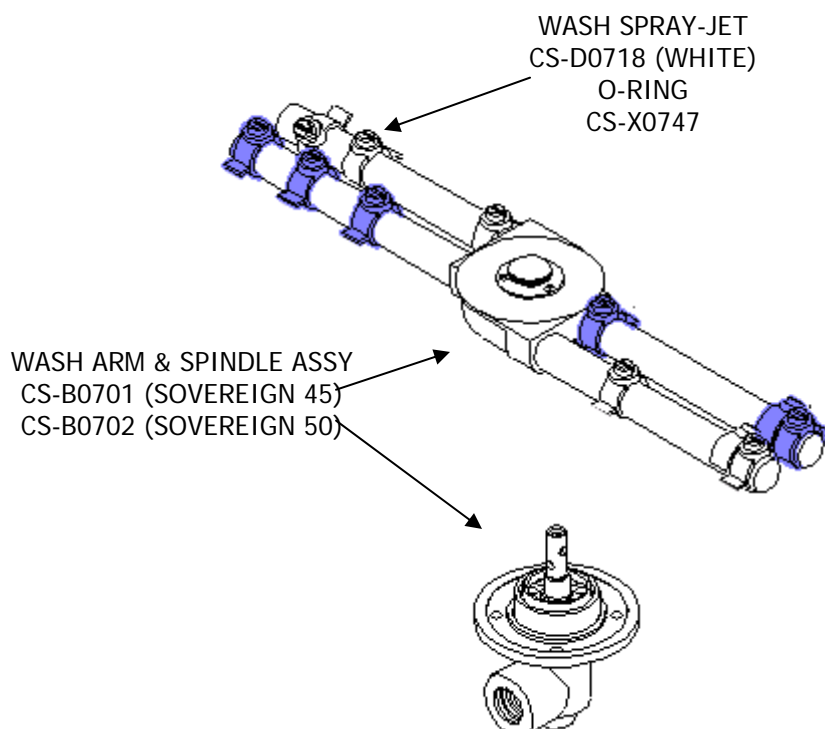
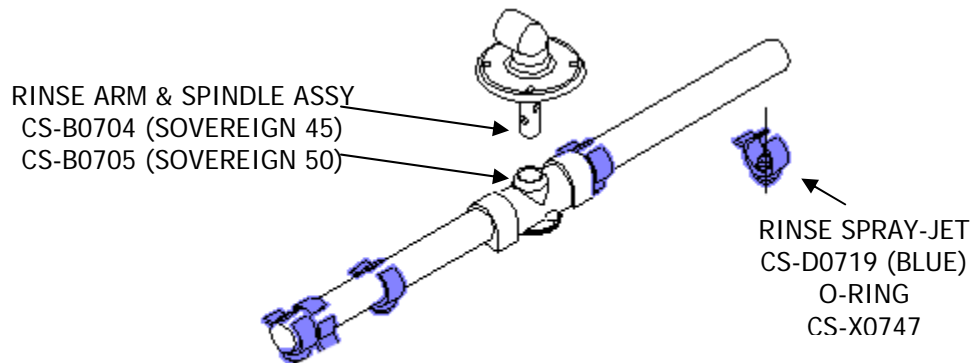

MAIN TRAY FILTER
CS-D0316

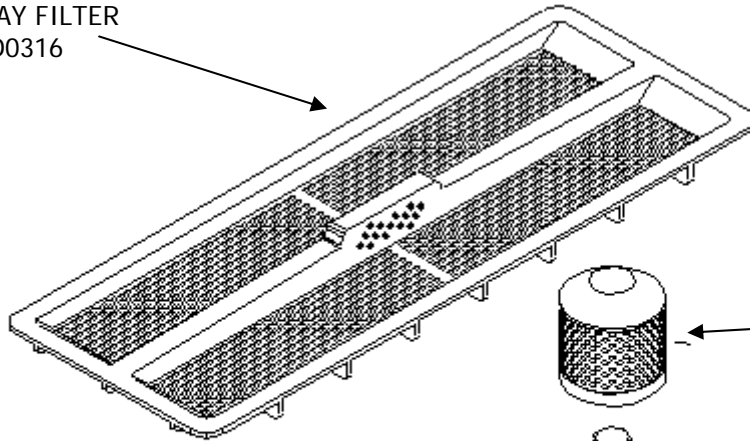

DRUM FILTER
CS-B0304



FLAT DISC FILTER (WASH)
CS-F0333



FLAT DISC FILTER (DRAIN)
CS-F0332





Caring For Your Sovereign Glass Washer

Observance of the following will ensure maximum efficiency from your machine:

Please **“do”** the following:

Glass Preparation

- Remove all solid material such as cocktail sticks, fruit peel and pips etc.
- Ensure that glasses used for speciality coffees or other drinks containing cream or fatty residues are pre-rinsed prior to washing. Greasy substances in the wash water can coat glasses and greatly impair beer foam stability and gas release.
- Ensure that all drink residues are disposed of, prior to washing.

Glass Racking and Stacking

- Ensure that baskets are filled with inverted glasses to maximise capacity and minimise risk of breakages.
- Always store washed glasses in an inverted position on ventilated drip mats, or in baskets.

Machine Preparation And Use

- Ensure that the machine interior is thoroughly clean and free of debris.
- Remove and thoroughly clean all jets, filters, wash arms etc DAILY. Wash filters must be absolutely clean and located correctly for the machine to operate efficiently.
- Ensure that the Jets are located correctly and check the Spray Bars are free to rotate.
- Ensure that the detergent and rinse aid containers are sufficiently full for the anticipated use during the session. Use only quality detergents and rinse aids, designed for glass washing.



- Ensure that a Water Softener, where fitted, is regenerated regularly.
- Ensure that the Fill/Ready Lamp is green before starting a cycle.
- Ensure that a wash cycle is fully completed before removal of glasses. On completion of a cycle, the Start Switch will stop rotating, and there will be five beeps by the audible alarm.
- Operate a Closedown Cycle to drain the machine completely after every trading session.
- Leave the door open at the end of session to ventilate the machine.

Please **“do not”** do the following:

- Put ashtrays, coffee cups or anything other than drinking glasses through the machine.
- Attempt to remove the basket of glasses before the Wash Cycle is completed.
- Wash glasses with water only. Detergent and Rinse Aid must be used.
- Stack glasses on top of each other.
- Leave washed glasses in the machine.
- Handle glasses during the drying period, or use a glass cloth. Allow the glasses to dry naturally, or with the aid of an Airack.
- Leave the door open between cycles.
- Isolate power without operating a Closedown Cycle.
- **Attempt to remove machine covers.**



Simple Fault Finding

Should a problem develop with your Sovereign machine, please consult the following fault-finding procedures before calling for assistance.

Service Lamp Flashes

- The Sovereign machine is designed to keep operating regardless of most functional errors that might occur. For example, for an internal heater failure, the machine will still operate, but with no internal heating.
- In most cases, the machine will resolve the fault, but for some errors the machine will be inoperative.

If you experience continued error flashes on the service lamp, or if the machine stalls, isolate the electrical supply for 10 seconds, re-connect and attempt to re-start the machine.

- If the problem persists, call for assistance.

Machine Will Not Switch On

- Check the switch is "ON" at the wall socket.
- Isolate the electrical supply for 10 seconds, re-connect and attempt to re-start the machine.
- Check for operation of circuit breakers or fuses in distribution box.
- Call for assistance.

Machine Does Not Fill

This fault usually generates a warning on the control panel.

The Service Lamp will flash with the frequency of 3 flashes and 1 pause

- Check that the water supply is switched on, and that a water supply is available.
- Check that the Inlet Hose is not kinked.



- If a Water Softener is fitted, check that the softener is not regenerating.
- Call for assistance.

Machine Will Not Drain

- Check for blocked drain filter.
- Call for assistance.

Machine Filled Okay, But Washtank Is Empty

- Check for water siphoning out of the machine due to the Drain Outlet Hose being pushed too far down the waste up-stand.
- Call for assistance.

Machine Will Not Operate A Wash Cycle

- Check that the Fill/Ready Lamp is lit 'green', and that the door is closed.
- Call for assistance

Glasses Remain Soiled

- Ensure that glasses used for speciality coffees or other drinks containing cream or fatty residues are pre-rinsed prior to washing.
- Remove all drink residues and solid material such as cocktail sticks, fruit peel and pips etc prior to washing.
- Check that the Rotation lamp on the control panel is lit 'green'. If lit 'amber', check that both Spray-Bars rotate freely, and that no Spray-Jets are blocked or missing.
- Check that the Detergent and Rinse-Aid lamps on the control panel are lit 'green'. If lit 'amber', replace the relevant chemical.



- Check that chemical suction tubes are correctly in position in the containers. The 'clear' tube should be fed by the detergent container, and the 'blue' tube fed by the Rinse-Aid container.
- Ensure that quality chemicals designed for glass washing are in use.
- Check that the water softener (where fitted) is being regenerated with granular salt at frequent intervals.
- Call for assistance.

Glasses Not Shedding ("Spotty" In Appearance)

- Ensure that the wash cycle has completed before removing the basket of washed glasses from the machine.
- Ensure that the glasses are not being polished with a cloth that has been treated with fabric conditioner.
- Check that the Detergent and Rinse-Aid lamps on the control panel are lit 'green'. If lit 'amber', replace the relevant chemical.
- Check that chemical suction tubes are correctly in position in the containers. The 'clear' tube should be fed by the detergent container, and the 'blue' tube fed by the Rinse-Aid container.
- Ensure that quality chemicals designed for glass washing are in use.
- Check that the Rotation lamp on the control panel is lit 'green'. If lit 'amber', check that both Spray-Bars rotate freely, and that no Spray-Jets are blocked or missing.
- Check that the water softener (where fitted) is being regenerated with granular salt at frequent intervals.
- Where plastic glasses are in use, always select the Plastics Wash Cycle.



- The Sovereign machine is equipped with a Renovate Cycle. Glasses can be put through a Renovate Cycle (using Renovate Powder) to remove any build-up of contamination. Renovating glassware is recommended at regular intervals. Brand new glassware should also be renovated prior to using.
- Call for assistance.

Glasses "Smeary" or "Greasy" In Appearance

- Ensure that glasses used for speciality coffees or other drinks containing cream or fatty residues are pre-rinsed prior to washing.
- Remove all drink residues and solid material such as cocktail sticks, fruit peel and pips etc prior to washing.
- Check that the Detergent and Rinse-Aid lamps on the control panel are lit 'green'. If lit 'amber', replace the relevant chemical.
- Check that chemical suction tubes are correctly in position in the containers. The 'clear' tube should be fed by the detergent container, and the 'blue' tube fed by the Rinse-Aid container.
- Ensure that quality chemicals designed for glass washing are in use.
- Check that the Rotation lamp on the control panel is lit 'green'. If lit 'amber', check that both Spray-Bars rotate freely, and Spray-Jets are clear and in position.
- Ensure all wash filters for blockages and ensure they are correctly positioned.
- The Sovereign machine is equipped with a Renovate Cycle. Glasses can be put through a Renovate Cycle (using Renovate Powder) to remove any build-up of contamination. Renovating glassware is recommended at regular intervals. Brand new glassware should also be renovated prior to using.
- Call for assistance.



Machine Noisy In Wash Cycle

- Check that the wash tank filter has been fitted properly.
- Check that there is water in the wash tank.
- Check the wash tank filters for blockages.
- Call for assistance.

Excessive Foam In Cabinet

- Ensure that quality chemicals designed for glass washing are in use.
- Check that chemical suction tubes are correctly in position in the containers. The 'clear' tube should be fed by the detergent container, and the 'blue' tube fed by the Rinse-Aid container.
- Ensure that the wash filters are in position in the wash tank.
- Call for assistance.

Scale Build-up In Machine

- Check that the water softener (where fitted) is being regenerated with granular salt at frequent intervals.
- If the machine is connected to a hard water supply, chemicals designed for hard water, a Water Softener, or Filter should be considered.



Machine Errors

If the machine experiences a major error, this is indicated by the Service Lamp flashing red.



Description of errors:

Overfill Error (code '1')

- The Service Lamp will flash at a rate of – 1 Flash and 1 Pause
- The machine will be unusable.
- Closedown the machine and call for an engineer.

Overfill Error (code '2')

- The Service Lamp will flash at a rate of – 2 Flashes and 1 Pause
- The machine will be unusable.
- Closedown the machine and call for an engineer.

Fill Error (code '3')

- The Service Lamp will flash at a rate of – 3 Flashes and 1 Pause
- Machine stalls, but will resume if water supply is restored.
- Check water supply. If problem persists Closedown the machine and call for an engineer.



Refill Error (code '4')

- The Service Lamp will flash at a rate of – 4 Flashes and 1 Pause
- The machine will be unusable.
- Closedown the machine and call for an engineer.

Rinse Timeout Error (code '5')

- The Service Lamp will flash at a rate of – 5 Flashes and 1 Pause
- The machine will be unusable.
- Closedown the machine. Check and clean the rinse jets, and restart the machine.
- If problem persists, call for an engineer.

Note: To Closedown the machine, press the **SELECT** Switch, followed by the **START** Switch.



Sovereign Glass Washer Installation

Electrical Connection

IMPORTANT: Electrical connection must be carried out by a competent electrical engineer

WARNING: THIS APPLIANCE MUST BE EARTHED

The wires in the mains lead supplied are coloured in accordance with the following code:

Green/Yellow	-	Earth
Blue	-	Neutral
Brown	-	Live

As the colours of the wires in the mains lead of this appliance may not correspond with the colour markings on your supply terminals, proceed as follows:

- The wire, which is coloured green and yellow, must be connected to the terminal marked "E" or by the earth symbol \equiv , or coloured green or green and yellow.
- The wire, which is coloured blue, must be connected to the terminal marked "N" or, coloured black.
- The wire, which is coloured brown, must be connected to the terminal marked "L" or, coloured red.

The following instructions **must** be followed before connecting to the electrical supply.

- Check that the supply voltage is within the range marked on the appliance rating plate.
- Ensure that the correct supply cable is fitted.



30 AMP (Recommended)

Sovereign machines are supplied from the factory internally wired for 30 amp (5.4 kW) operation and fitted with a 4mm² Mains Cable. Connection **must** be made to a **30 amp** supply.

13 AMP (Optional)

Sovereign machines can be de-rated for operation on a 13 Amp supply by a competent engineer. This modification requires a change in mains cable type, and internal wiring changes.

Connect to the electrical supply via a double pole-isolating device incorporated in the fixed wiring with contact separation of at least 3mm located within one metre of the machine so that the switch is in an easily accessible position. If in doubt, consult a qualified electrician.

Use of a Residual Current Device is recommended.

Equipotential Bonding

This appliance is provided with a dedicated external terminal located on the lower rear cross member to facilitate the connection of an equipotential bonding conductor and is marked with the following symbol:-

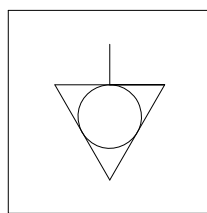

Instructions are supplied with the machine. Further information is available from Clenaware Systems Ltd.

Note: The power supply cord must be oil resistant, sheathed flexible cable not lighter than ordinary polychloroprene or other equivalent synthetic elastomer-sheathed cord (code designation HO5 RN-F).



Electrical Ratings

Voltage	230 - 240 V \sim 50Hz
Input (W)	5500 (as supplied) or 3000 (de-rated)
Current (A)	24 (as supplied) or 13 (de-rated)

Water Connection

Sovereign machine can be connected to mains or storage water. The use of cold water supply is recommended.

Water requirements:

- Hot or Cold 50 – 1000 kPa (0.5-10 bar) @ 5 litres/min (minimum)

NOTE: Maximum hot water supply temperature 60°C

Connection is by flexible hose, which terminates with a $\frac{3}{4}$ " BSP female fitting. Supply must be terminated with a $\frac{3}{4}$ " BSP male threaded tap for machine isolation, and positioned within one metre of the machine.

Cold water connection is recommended for optimum washed glass quality.

The Sovereign Glasswasher incorporates an integral pumped rinse system, therefore external booster pumps are not required and should not be connected.

Drain Connection

This machine has a pumped waste system and requires a trapped 1½" open vent upstand with the top 450mm from the base of the machine. Place non-kink hose and former into upstand.

Detergent And Rinse Aid Connection

Injection is automatic. The end of the suction hoses (clear for detergent and blue for rinse aid) should be fitted with the supplied caps, weights and filters and placed into the base of the relevant containers.



Siting

The machine must be sited on a sound level surface, with adequate clearance for servicing. Allow 50mm extra width and height clearance to ensure ventilation around the machine, and aid servicing. Be sure to provide allowance for water, drain, and electrical connections, and for the positioning of two 5lt Chemical Bottles.

Electrical

This machine is suitable for 13 or 30 Amp connection (supplied ready for 30 Amp operation). 30 Amp operation is recommended. Modification to 13 Amp operation is made at the time of installation with internal wiring changes and fitting a 15 Amp Mains Cable. Refer to the Owners Manual Installation Instructions, and/or enclosed instructions.

- 13 Amp: A 1.5mm sq Mains Cable can be terminated with a 13 Amp Fused Plug-Top (to BS1363) for connection into a Socket Outlet, or alternatively, the mains cable can be wired directly into a Double Pole Switched and Fused Spur Outlet (with contact separation of at least 3mm in all poles). The machine must be fused at 13 Amps.
- 30 Amp: A 4mm sq Mains Cable (fit as standard) must be wired directly into a Double Pole Isolating Switch (with contact separation of at least 3mm in all poles). The machine must be fused at 25 Amps.

The Socket or Switched Spur Outlet must be on the wall to the rear and side of the machine, away from any water hazard, and positioned within one metre of the machine. It must be accessible for isolation.

This machine MUST be Earthed. Use of a Residual Current Device is recommended.

Water

A Hot or Cold water supply can be connected. A cold water supply is recommended, in conjunction with a 30 Amp electrical supply. If a hot water supply is connected, this must not exceed 60°C.

The water supply must terminate with an easily accessible ¾" BSP Bibcock positioned within one metre of the machine.



These machines incorporate integral Break Tanks which have a Type 'A' Airgap which comply with the requirements of WRC IRN 001 (Category '5' Risk). The machine can be connected to storage, or direct to Mains Water Supply.

If the Water Hardness exceeds 8° Clark or 120 mg/l (ppm), chemicals designed for hard water must be used. Water Softeners are not required.

Waste

This machine has Pumped Waste System which requires a trapped open-vent up-stand, a minimum of 450mm from the base of the machine.

Part No	1025	1026
Rack Size	450mm sq	500mm sq
Height Clearance	250mm	250mm
Rack Capacity (Pint Nonic)	24	30
Cycle Time	2 mins	
Supply Voltage	240V 50Hz	
Power Input	3 or 5.1 Kw	
Fuse @	13 or 25 Amps	
Wash Pump Power	300 W	
Wash Tank Capacity	3 lts	3½ lts
Rinse Pump Power	300 W	
Rinse Tank Capacity	3 lt's	3½ lt's
Rinse Heater Power	2.5 or 5 Kw	
Rinse Temperature	65°C	
Wash Temperature	55 – 60 °C	
Rinse Water per Cycle	3 lt's	3½ lt's
Water Pressure Hot	0.5–1.5 Bar @ 5lt/min	
Cold	0.5–10 Bar @ 5lt/min	
Waste	Pumped	
Rinse-Aid Dosing	Standard & Adjustable	
Detergent Dosing	Standard & Adjustable	
Descale Function	Optional	
Thermal Insulation	Full	
Operating Weight	64.5Kg	77Kg
Shipping Weight	63Kg	75Kg

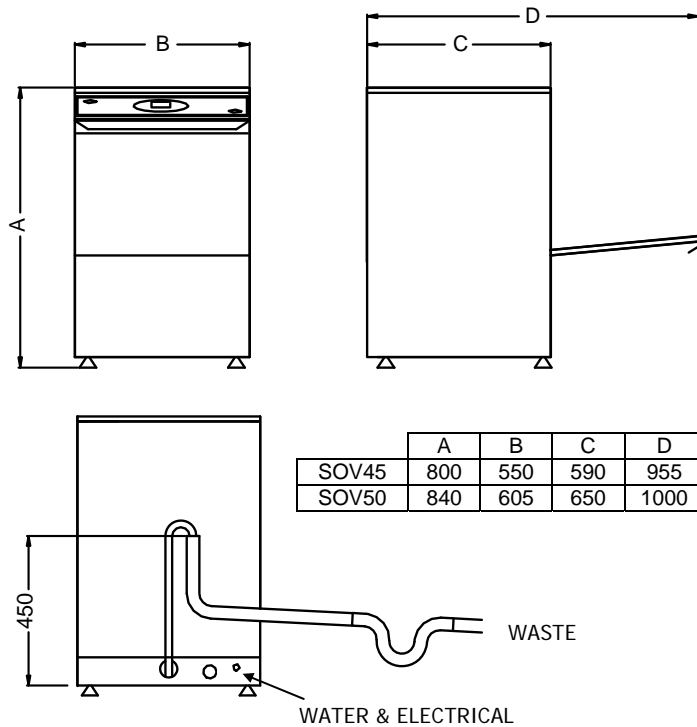

Clenaware Systems Ltd reserve the right to amend specifications

WEEE

This equipment contains electrical and electronic components.

At the end of its life, this equipment should not be mixed with general waste during disposal.

For proper treatment, recovery and recycling, please take this equipment to a designated recycling facility. Please contact your local authority for further details of your nearest designated recycling facility.

Alternatively, you can contact your supplier of the equivalent new product to arrange disposal.

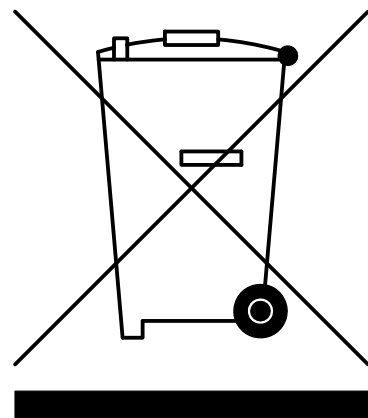



Service And Warranty

Warranty

All Clenaware Systems machines are covered by a 12 month guarantee.

Clenaware Systems Ltd guarantee that any and all products manufactured and marketed under the Clenaware Systems name and used in the correct way are free from defects in material and/or workmanship for a period of 12 months from the date of first installation.

All repairs will be carried out Monday to Friday and between the hours of 9.00 and 17.30.

The Clenaware Systems warranty covers any material or manufacturing and we will repair or replace any defect provided that:

- 1: Installation and commissioning was carried out by Clenaware Systems or an approved / nominated agent in accordance with the Clenaware Systems requirements as detailed in the user manual.
- 2: Products and/or components are not modified, altered or dismantled by unauthorised persons.
- 3: Products are maintained in accordance with the Clenaware Systems requirements by Clenaware Systems or an approved / nominated agent.
- 4: Products are cleaned and preventative maintenance carried out in accordance with the Clenaware Systems requirements as detailed in the owner's manual and on the care card.
- 5: Warranty service is performed by Clenaware Systems or an approved / nominated agent using genuine Clenaware Systems replacement parts supplied by Clenaware Systems or an approved / nominated agent.



- 6: A maintenance service has been carried out by Clenaware Systems or an approved / nominated agent at 12 months from purchase/installation. This is chargeable to the customer.
- 7: That chemicals used during normal operating are those recommended and purchased from Clenaware Systems or an approved / nominated agent.

The Clenaware Systems warranty will not cover the following:

- 1: Failure or damage caused by misuse, accidental or malicious damage.
- 2: Failure or damage caused by the loss of or fluctuations in electrical power supply.
- 3: Failure or damage caused by water supply failure or any other plumbing or drainage problem. This includes any water treatment device connected to the product.
- 4: Labour and material costs associated with cleaning and preventative maintenance as detailed in the owners manual or failure to perform a 12 month service.
- 5: Labour and material costs associated with replacing filters or other water treatment devices.
- 6: Labour and material costs where non recommended chemicals are used causing failure due to corrosion, loss of beer-head retention, taste, appearance, cleanliness of washed glassware, or the formation of lime scale within the machine.
- 7: Labour and material costs associated with failure or operating problems caused by incorrect installation.
- 8: Any consequential loss as a result of product failure.
- 9: No fault found calls, these will be chargeable to the customer.
- 10: Costs associated with repairs requested out of hours i.e. before 09.00 hours and after 17.30 hours, Monday to Friday, all day Saturday, Sunday and Public Holidays.



Service

Warranty

- 1: All warranty service is performed by Clenaware Systems or an approved / nominated agent.
- 2: Warranty service is performed Monday to Friday and between the hours of 09.00 and 17.30.
- 3: All warranty claims should be logged by calling : **01933 666244**

Please have the following details to hand to speed up the processing of your call:

- a) Machine Serial Number
- b) Site Name
- c) Contact Name & Telephone Number
- d) Access Times
- e) Description of problem

When calling please try to avoid "Out Of Order", "It's Faulty" or "Not Washing Correctly" as the "Description of problem".

Maintenance & Servicing

- 1: A number of different types of service contract are available through Clenaware Systems or an approved / nominated agent.
- 2: All enquiries should be logged by calling : **01933 666244**
- 3: For further information or clarification on warranty and service please contact Clenaware Systems using the details on the last page of this document.



Disclaimer

- 1: Installation and commissioning of the Clenaware Systems machines should be carried out by Clenaware Systems or an approved / nominated agent in accordance with the Clenaware Systems requirements as detailed in the user manual. Failure to install and commission a machine in line with these requirements can invalidate the warranty.
- 2: As part of a process of ongoing innovation and brand development, Clenaware Systems reserves the right to change specifications without prior notice.
- 3: Brand Names, Trade Marks, Trade Names, Images and Drawings used in any documents relating to a Clenaware Systems product are for reference purposes only and should not be reproduced without the written permission of Clenaware Systems Ltd.



CLENARE SYSTEMS LTD

Main Office : +44 (0) 1933 666244

Fax: +44 (0) 1933 665 584

Web: www.clenaware.co.uk

Email: info@clenaware.co.uk



Main Office Address

The Wagon Hovel
Strixton Manor Business Centre
Strixton. Wellingborough
Northants. NN29 7PA

Factory Address

30 Huxley Close
Park Farm Industrial Estate
Wellingborough
Northants. NN8 6AB